



Digital Security Screening System

SECURPASS

Full Body Security Screening System

Detect, Recognize &
Secure in **8 Seconds**

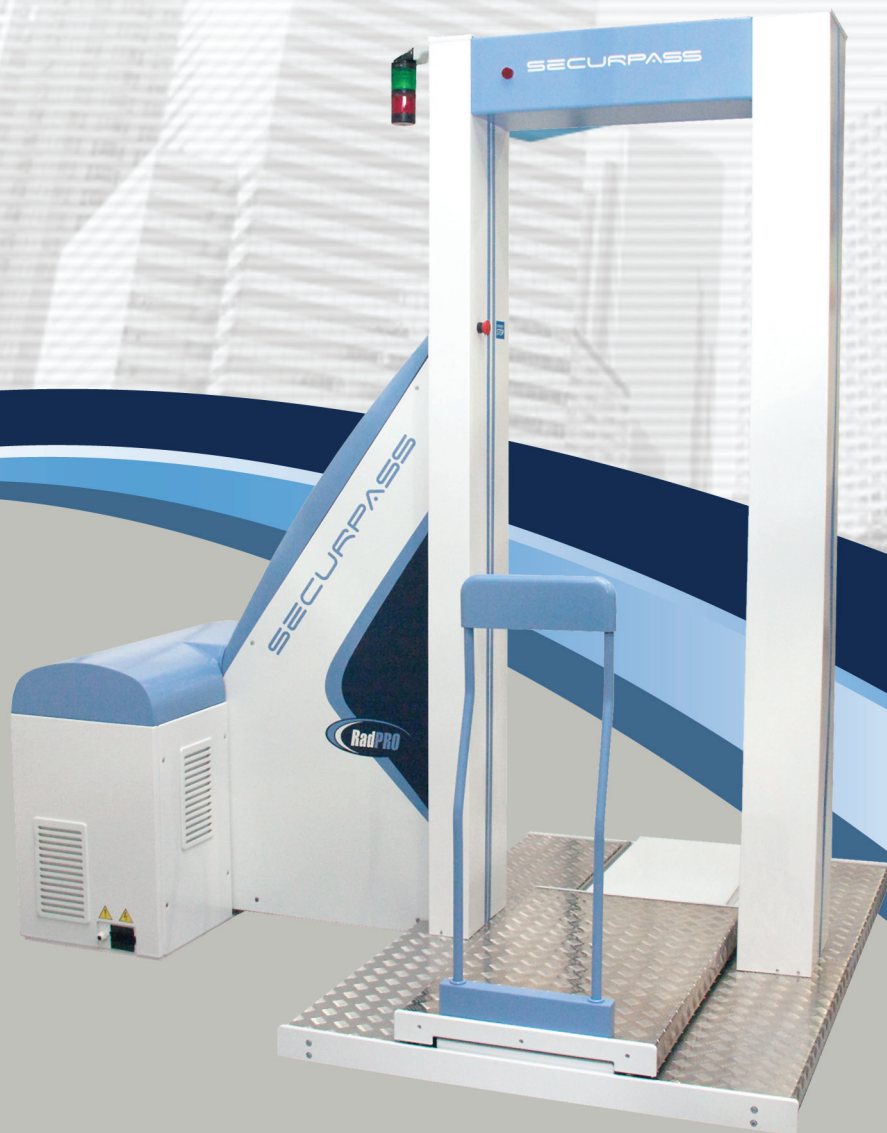

Maximize Security / Minimize Physical Searches

The RadPRO SECURPASS is capable of handling the high level security needs at airports, prisons, border crossings and government buildings. Based on unique patented technology, this Low dose X-ray screening system detects dangerous, illegal substances such as liquid explosives, drugs, copper wires and plastics.

FEATURES / SPECIFICATIONS

- Open, obstruction free gantry
- Quick, consistent checkpoint passage
- Detect dangerous metallic and non-metallic items
- Passenger friendly inspection of shoes/clothing without removal
- Extreme low radiation dosage for single inspection
- Inspection privacy: system does not reveal skin surface or fine anatomical detail
- Hardened steel platform certified to 660 lbs

■ APPLICATIONS

- **Civil Security:** airports, seaports, railways, bus stations
- **Border Security:** customs, police
- **Prison Security:** officers, prisoners, visitors, staff
- **High Level Security:** nuclear power plants, military premises, embassies, etc

■ GENERAL

Scan Area	81.9 x 29.1 in (208 x 74 cm)
Scanning Time	under 8 seconds
Penetration (steel)	1.18 in (30 mm)

■ RESOLUTION

Spatial	30 AWG (0.25 mm)
---------	------------------

■ GENERATOR

Configuration	Monoblock oil cooled design
Anode Voltage	150 kV

■ DOSE / INSPECTION

Screening Model (4,000/y/subject)	< 0.25 uSv (0.025 mR) / per scan
-----------------------------------	----------------------------------

■ IMAGING SYSTEM

Monitor	21" monitor (portrait)
Grayscale	16,384 (image)
Local Storage	960,000 images 1T Hard Drive, Mirrored with a 1T Backup Drive
Image Visualization Time	Real Time
Power	220 V / 110 V, 50 Hz / 60 Hz, 2 kW

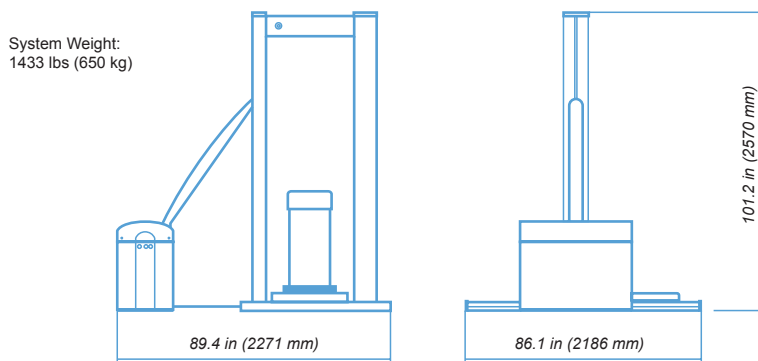

Security Screening System

Low dose X-ray scanning system that detects all types of dangerous or illegal substances such as liquid explosives, drugs, copper wires, plastics, etc. Based on unique patented technology, **SECURPASS** is capable of handling the high level security needs at airports, prisons, border crossings and government buildings.

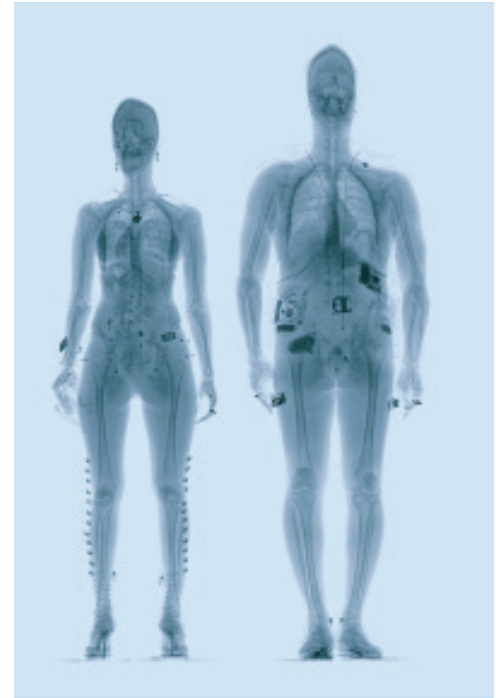

SECURPASS is able to image prosthetics to identify hidden narcotics, weapons, contraband, etc. (*Make-up, Medication, Personal Items, Special Needs Items, Electronic Devices, Sharp Objects, Sporting Goods, Guns/Firearms, Tools, Martial Arts/Self Defense Items, Explosive/Flammable Materials, Disabling Chemicals, Food/Drinks*) and any objects that could be considered as dangerous.

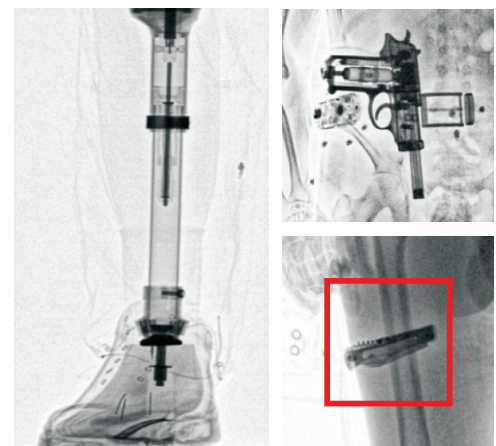

Canon

MAS Security Solutions
2021 Midwest Road, Suite 200
Oak Brook, Illinois 60523
800-441-6274
www.massecurityimaging.com